

## 7017X Series Surface Mount LEDs 0603 Package Size

### Description and Features

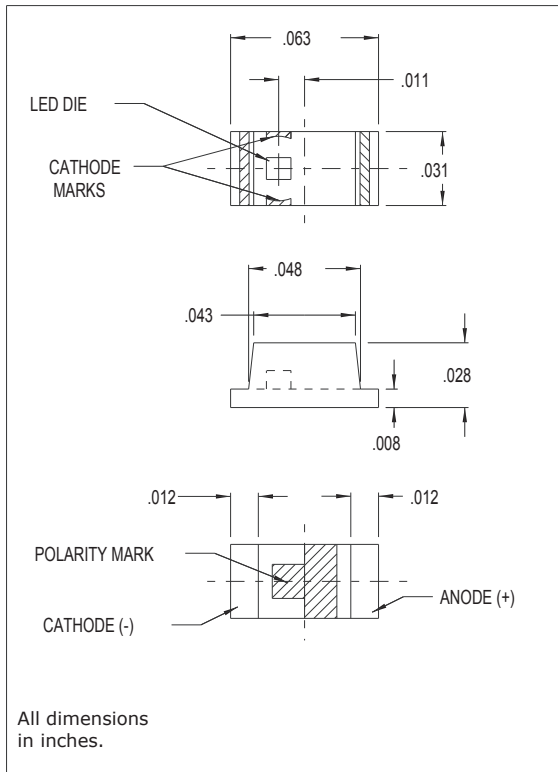

#### Surface Mount Technology

- Tape and reel packaged for high-speed autoinsertion.
- Convection and vapor-phase reflow compatible.
- Compact form enables high density placement.
- Packaged 4000 pieces per reel.

#### Leading Edge LED Optoelectronic Performance

- Consistent high brightness.

#### Exceptional Reliability

- Stringent process controls assure quality.
- Extensive qualification testing to meet strictest requirements.
- Designed to permit easy post-reflow solder joint inspection.

## Electro-Optical Characteristics and Ratings

PART NUMBER	7017X15	7017X1	7017X1	7017X1
Output Color	Green	Red	Yellow/Green	Yellow
Diffusion	Diffused	Diffused	Diffused	Diffused
Package Color	Clear	Clear	Clear	Clear
Test Current (mA)	20	5	20	20
Forward Voltage Typ. (V)	2.1	1.9	2.1	1.9
Forward Voltage Max. (V)	2.8	2.1	2.8	2.4
Luminous Intensity Min. (mcd)	1.4	10	7.0	16
Luminous Intensity Typ. (mcd)	2.4	20	11.7	65
Luminous Intensity Max. (mcd)	-	64	-	-
Peak Wavelength (nm)	555	635	570	592
Viewing Angle 20 1/2 (degrees)	70	70	70	70
Power Dissipation (mW)	70	81	70	81
Operating Temperature (°C)	-30 to +85	-40 to +85	-30 to +85	-40 to +85
Storage Temperature (°C)	-40 to +100	-40 to +100	-40 to +100	-40 to +100
Peak Forward Current Max. (1µs @ 10% duty cycle) (mA)	60	100	60	100
Reverse Voltage (IR=100µA) (V)	4	5	4	5
Lead Solder Time @ 260°C	5	5	5	5