



NOTES

1. ROHS COMPLIANT
2. MATERIALS:  
 FIBER OPTIC: 1.5MM DIA SUPER OPTICAL CORE , 2.2MM DIA POLYETHYLENE CABLE JACKET  
 LENS MOUNT: OPTICAL GRADE ACRYLIC  
  
 LED MOUNTS: NYLON 66, UL RATING 94-V2  
 LENS: POLYCARBONATE UL RATING 94-V2  
 LENS WASHER: FH STEEL, NICKEL PLATE  
 LENS RETAINING RING: THERMOPLASTIC U.L. 94-V0 RATED  
 LENS SEAL: EPDM
3. OPTICAL CORE ENDS POLISHED TO 10 MICRONS.
4. MOUNTS THROUGH FRONT OF PANEL. SECURED BY RETAINING RING.
5. LENSES MOUNT THROUGH A 5/16" HOLE ON 1/2" CENTERS.
6. PANEL THICKNESS 1/32" TO 1/8".
7. FOR BEST RESULTS USE ONLY NARROW VIEWING ANGLE NON-DIFFUSED LEDS WITH OUTPUT POWER GREATER THAN 100mcd.
8. U.S. AND FOREIGN PATENS ISSUED.

REVISIONS					
ZONE	ECN #	REV.	DESCRIPTION	DATE	INITIALS
		001	INITIAL RELEASE	7-8-09	SMU

LIGHT PIPE ASSEMBLY  
 ORDERING CODE (EXAMPLE): **FLX 442 BTP 06**

LENS TYPE CODE	
441	CMC 441, STANDARD FRESNEL
442	CMS 442, MOISTURE-SEALED FRESNEL
443	CMC 443, PLAIN END
444	CMS 444, MOISTURE-SEALED PLAIN END
	CMC 441 & CMC 443, INCLUDES LENS CLW 441 LOCK WASHER RTN 441 RETAINING RING
	CMS 442 & CMS 444, INCLUDES LENS W/ SEAL (EXCEEDS NEMA 4) CLW 441 LOCK WASHER RTN 441 RETAINING RING

LENS COLOR	
RTP	RED TRANSPARENT
ATP	AMBER TRANSPARENT
GTP	GREEN TRANSPARENT
BTP	BLUE TRANSPARENT
YTP	YELLOW TRANSPARENT
CTP	CLEAR TRANSPARENT

FIBER LENGTH CODE	
02	2.0"
04	4.0"
06	6.0"
08	8.0"
12	12.0"
CUSTOM LENGTHS AVAILABLE	

MOUNTING OPTIONS (ORDER SEPARATELY)

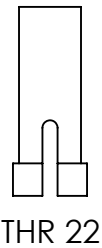
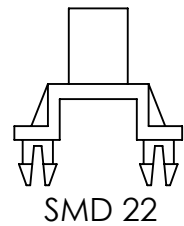

PANEL INSTALLATION

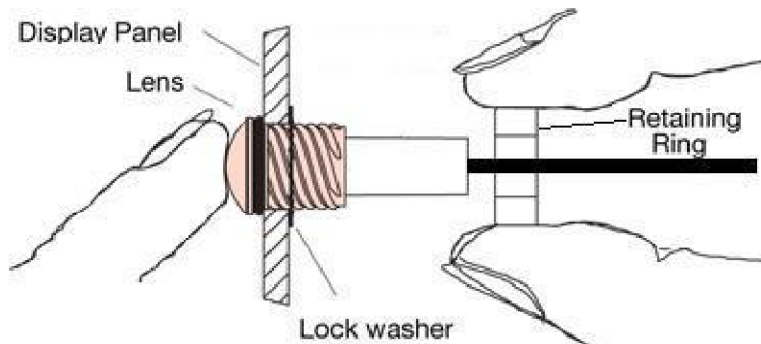

INSERT LENS THROUGH PANEL HOLE. FROM THE BACK SIDE SLIP THE LOCK WASHER ONTO LENS BARREL. WHILE HOLDING LENS, TWIST ON RETAINING RING ONE REVOLUTION UNTIL SECURE.

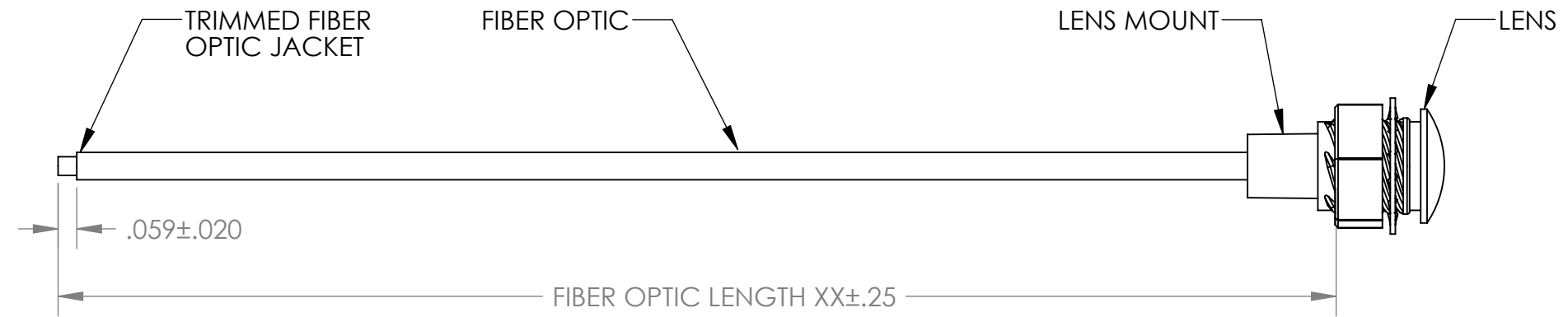

UNLESS OTHERWISE SPECIFIED DIMENSIONS ARE IN INCHES  
 ANGLES DECIMALS  
 ±03' .X ±.030  
 FINISH .XX ±.015  
 63 .XXX ±.004  
 ✓ BREAK ALL CORNERS AND SHARP EDGES .030 MAX

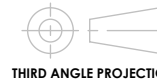

PROPRIETARY AND CONFIDENTIAL

THE INFORMATION CONTAINED IN THIS DRAWING IS THE SOLE PROPERTY OF VISUAL COMMUNICATIONS COMPANY, INC. ANY REPRODUCTIONS IN PART OR AS A WHOLE WITHOUT THE WRITTEN PERMISSION OF VISUAL COMMUNICATIONS COMPANY IS PROHIBITED

	INITIALS	DATE
DRAWN	SMU	7-8-09
CHECKED	AZ	7-14-09
ENG APPR.	DPZ	7-14-09
PURCH.		
Q.A.		
MFG APPR.		
MATERIAL:		
FOR:		

**Visual Communications Company**  
 190 Bosstick Boulevard, Suite 101  
 San Marcos, CA 92069 USA

DWG. NO.

FLX 44X XTP XX

SIZE	TITLE:	REV:
<b>B</b>	FLX 44X ASSEMBLY	001

SCALE: 1:1      WEIGHT: LBS      SHEET 1 OF 1