

REVISIONS					
ZONE	ECN #	REV.	DESCRIPTION	DATE	INITIALS
		001	INITIAL RELEASE	7-8-09	SMU

LIGHT PIPE ASSEMBLY
ORDERING CODE (EXAMPLE): **FLX 322 BTP 06**

LENS TYPE CODE	
322	CMS 322, LOW PROFILE FRESNEL LENS WITH MOISTURE SEAL. INCLUDES SEAL AND RETAINING RING.

LENS COLOR	
RTP	RED TRANSPARENT
ATP	AMBER TRANSPARENT
GTP	GREEN TRANSPARENT
YTP	YELLOW TRANSPARENT
BTP	BLUE TRANSPARENT
CTP	CLEAR TRANSPARENT
GLO	CLEAR TRANSLUCENT

FIBER LENGTH CODE	
02	2.0"
04	4.0"
06	6.0"
08	8.0"
12	12.0"
CUSTOM LENGTHS AVAILABLE	

- NOTES
1. ROHS COMPLIANT
 2. MATERIALS:
FIBER OPTIC: 1.5MM DIA OPTICAL CORE , 2.2MM DIA POLYETHYLENE CABLE JACKET
LENS MOUNT: OPTICAL GRADE ACRYLIC

LED MOUNTS: NYLON 66, UL RATING 94-V2
LENS: POLYCARBONATE UL RATING 94-V2
LENS RETAINING RING: POLYPROPYLENE
LENS SEAL: J-VON
 3. OPTICAL CORE ENDS POLISHED TO 10 MICRONS.
 4. MOUNTS THROUGH FRONT OF PANEL. COMPRESSION OF THE SEAL IS ACCOMPLISHED BY PRESSING THE RETAINING RING IN PLACE.
 5. LENSES MOUNT THROUGH A 9/32" HOLE ON 3/8" CENTERS.
 6. PANEL THICKNESS 1/32" TO 1/8".
 7. FOR BEST RESULTS USE ONLY NARROW VIEWING ANGLE NON-DIFFUSED LEDS WITH OUTPUT POWER GREATER THAN 100mcd
 8. U.S. AND FOREIGN PATENS ISSUED.

MOUNTING OPTIONS
(ORDER SEPARATELY)

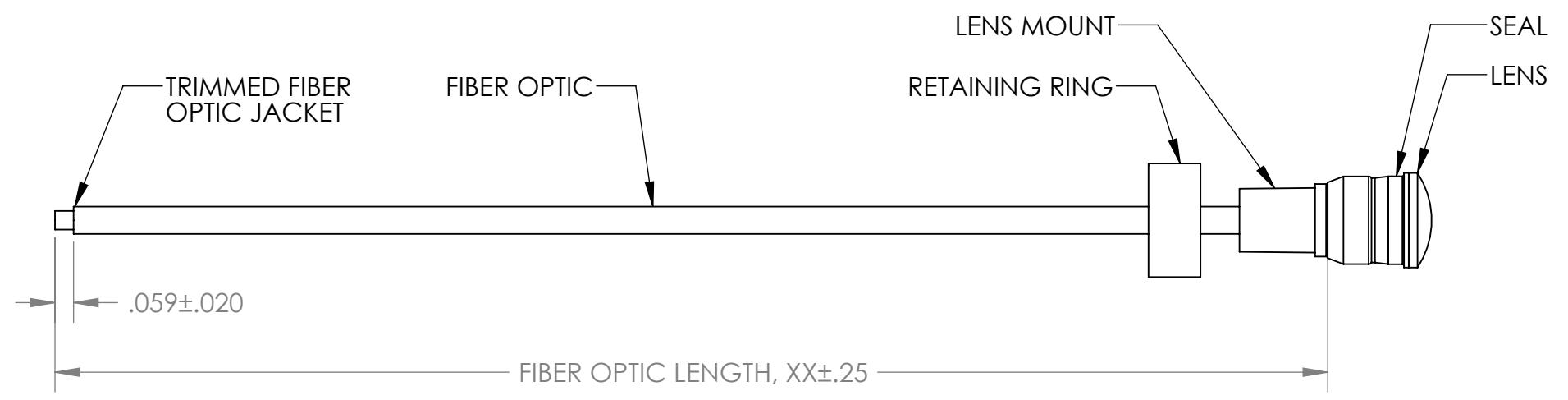
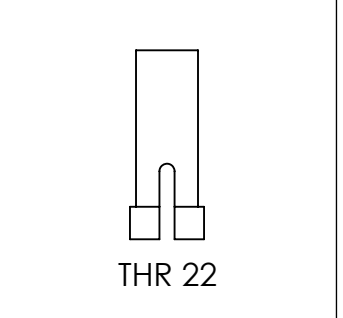
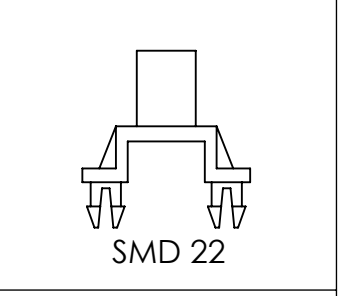

PANEL INSTALLATION

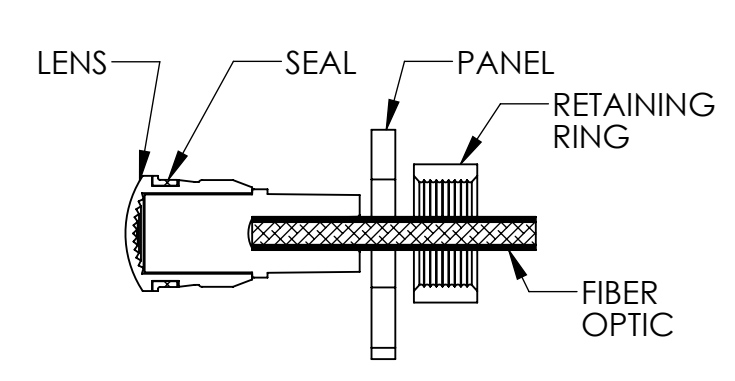

INSTALL LENS THROUGH 9/32" PANEL HOLE.
PRESS RING ONTO LENS TO COMPRESS SEAL.

UNLESS OTHERWISE SPECIFIED DIMENSIONS ARE IN INCHES

ANGLES	DECIMALS
±03'	.X ±.030
FINISH	.XX ±.015
63	.XXX ±.004

✓ BREAK ALL CORNERS AND SHARP EDGES .030 MAX



PROPRIETARY AND CONFIDENTIAL

THE INFORMATION CONTAINED IN THIS DRAWING IS THE SOLE PROPERTY OF VISUAL COMMUNICATIONS COMPANY, INC. ANY REPRODUCTIONS IN PART OR AS A WHOLE WITHOUT THE WRITTEN PERMISSION OF VISUAL COMMUNICATIONS COMPANY IS PROHIBITED

	INITIALS	DATE
DRAWN	SMU	7-8-09
CHECKED	AZ	7-14-09
ENG APPR.	DPZ	7-14-09
PURCH.		
Q.A.		
MFG APPR.		
MATERIAL:		
FOR:		

Visual Communications Company
190 Bosstick Boulevard, Suite 101
San Marcos, CA 92069 USA

DWG. NO. FLX 322 XXX YY

SIZE: **B** TITLE: FLX 322 ASSEMBLY REV: 001

SCALE: 1:1 WEIGHT: LBS SHEET 1 OF 1