

8 7 6 5 4 3 2 1

NOTES:

1. MOUNTING: Mounts in a $\phi .281 \pm .002$ [$\phi 7.13\text{mm} \pm .05$] panel hole on .375 [9.5mm] centers. Panel thickness .031 [0.8mm] to .250 [6.35mm]. Panel hole should be deburred, but not chamfered.
2. ASSEMBLY: Insert lens through panel hole, slide RNG 268 retainer on back of lens. PCB mounted LEDs slide into lens when the panel cover is closed or the PCB card is inserted into the case.
3. MATERIAL: Polycarbonate, UL 94-V2
4. U.S. & Foreign Pat. Issued & Pend.

REVISIONS				
ECN#	REV.	DESCRIPTION	DATE	INITIALS
	001	REVISED PER ECR111009AZ01	4-23-10	SMU

RETAINER
(ORDER SEPARATELY)

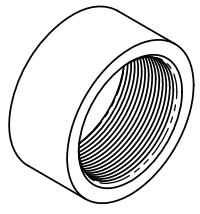

RNG 268

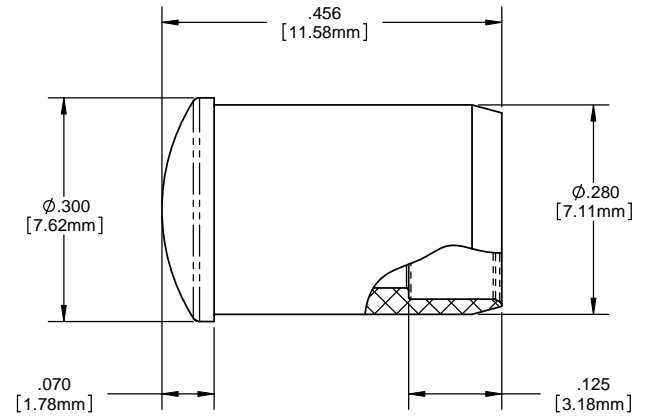
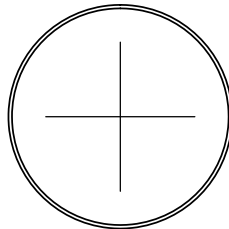
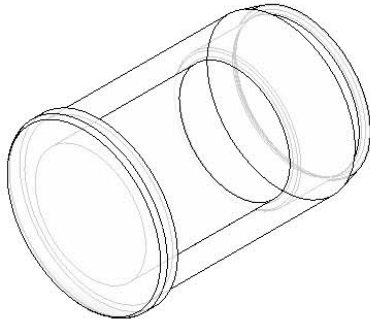

ORDERING CODE : **CML 327 XXX**

MODEL

LENS COLOR	
CTP	CLEAR TRANSPARENT

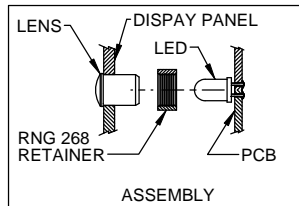

<small>UNLESS OTHERWISE SPECIFIED DIMENSIONS ARE IN INCHES</small> ANGLES DECIMALS $\pm 1^\circ$.X $\pm .020$ FINISH .XXX $\pm .010$.XXX $\pm .005$ BREAK ALL CORNERS AND SHARP EDGES 90 DEG	MATERIAL POLYCARBONATE, UL 94-V2	VISUAL COMMUNICATIONS COMPANY, INC. 190 Bossick Boulevard, Suite 101 San Marcos, CA 92069 USA Phone (760) 560-1300 Fax (760) 560-1301 email vccsales@vccite.com	
	FINISH SEE NOTES	TITLE: 5MM ROUND PLAIN END LENS	
THIRD ANGLE PROJECTION	APPROVAL	DATE	SIZE DWG. NO.
<small>PROPRIETARY AND CONFIDENTIAL</small> THE INFORMATION CONTAINED IN THIS DRAWING IS THE SOLE PROPERTY OF VISUAL COMMUNICATIONS COMPANY, INC. AND IS TO BE USED FOR THE PURPOSES SPECIFIED HEREIN. ANY REPRODUCTION IN PART OR AS A WHOLE WITHOUT THE WRITTEN CONSENT OF VISUAL COMMUNICATIONS COMPANY, INC. IS PROHIBITED.	DRAWN: SMU 4-23-10 CHECKED: DZ 4-23-10 DO NOT SCALE DRAWING	DATE: 4-23-10	SCALE: 1:1 SHEET 1 OF 1

8 7 6 5 4 3 2 1